



## **OPERATION MANUAL WATERFALL PUMP**

804748 - PM2 13000W

804749 - PM2 15000W

804750 - PM2 18000W





#### 1. **INSTRUCTION FOR USE**

Please read the operating instructions and familiarize yourself with the device before placing it in service. Correct and safe use of the pump requires strict compliance with the safety instructions. For safety reasons, children and young people under the age of 16 years, as well as people that cannot recognize potential hazards, and people who are not familiar with these instructions, should not use this device.



#### 2. **UNPACKING**

Notify your dealer immediately if there are any external damages.

#### 3. **CONVENTIONAL USE**

You can displace clean and dirty pond water and aquarium water with a temperature between +4°C and +35°C.

You can use the pump as follows:

- Operating a filter for garden ponds
- Operating a waterfall
- Operating a watercourse
- Operating a fountain
- Circulation for aquariums



#### 4. **SAFETY INSTRUCTIONS**

- For your own safety, please contact an electrical specialist in case of questions and problems.
- Before reaching into the water, always disconnect all power cords of devices used in the water.
- Use the pump only on a circuit with a ground contact. This type of outlet must have been installed according to the respective national directives for your state. Ensure that the PE conductor extends all the way to the pump.
- Never use installations, adapters, extension cords or connecting cords or connecting cords without ground contact.
- Ensure that the pump is supplied via a residual current device with a measured residual current of not more than 30mA.
- Electrical installations on garden ponds must correspond to the international and national installation directives.
- Only operate the pump if no one is in the water
- Do not carry or pull the pump by its cord
- Keep the power plug and all electrical connections dry at all times.
- The pump may not be operated if the cable or housing is defective.
- If the power cord of the pump is damaged, the pump must be replaced.
- Never displace any liquids other than water.
- The thermal overload protector will switch the pump off in an overheat situation and will automatically restart the pump once it has cooled down



#### 5. **PLACING IN SERVICE**

- Read and familiarize yourself with the safety instructions (Section 4) before placing the pump in service.
- Compare the line voltage (V) and frequency (Hz) of your electrical circuit with the data on the pump. This data must match.
- Fasten a hauling/lifting rope to the pump. Use this rope to pull the pump from the water. Make the necessary hose connections (if required), or install a fountain attachment after the installation, ensure that there are no air bubbles in the hose system (lay the hose on an incline)
- Install the pump horizontally on a fixed support at least 20cm under the water surface. Comply with the maximum permitted immersion depth.
- Do not place the pump directly in the pond floor mud/dirt; place the pump on a raised surface.
- Lay the power cord in a protected area to reduce the possibility of damage.
- Connect the pump to the electrical circuit.



#### **Important note:**

- Never operate the pump without water (dry run) or partially submerged.
- Never operate the pump without the filter casing as it protects the pump from coarse dirt that can lead to clogging of the impeller.

#### **Additional installation instructions:**

- Our specified outputs are always measured directly at the pump outlet (without hose connection and accessories). To achieve the highest possible pump output keep the hose connections as short as possible. Elbows angles and other connecting elements should be reduced to a minimum as they lessen the pump output.



## 6. MAINTENANCE/CLEANING

- Follow the safety instructions (Section 4)
- Clean the filter housing monthly, or if the pump capacity is reduced, by using a soft brush under running water.
- Clean the pump more often if in regular use.

### Cleaning the pump

- 1) Dismantle the filter housing.
- 2) Clean the pump with a soft brush under running water.
- 3) Remove any grime in the rotor through the gaps.

Warning: Never open the motor housing. LIFE THREATENING HAZARD!

## 7. WINTER CARE

- Remove the pump from the water
- Thoroughly clean the pump (see section 6.0)
- Check the pump for any obvious damage
- Store the pump in frost free conditions, in a container with water if possible.

**CAUTION:** Never immerse the connecting plug!

## 8. TROUBLE SHOOTING

Problem	Possible Cause	Solution
<ul style="list-style-type: none"> <li>• Pump does not turn on</li> </ul>	<ul style="list-style-type: none"> <li>• There is no power</li> </ul>	<ul style="list-style-type: none"> <li>• Check the electrical circuit</li> </ul>
<ul style="list-style-type: none"> <li>• Pump does not displace water</li> </ul>	<ul style="list-style-type: none"> <li>• Filter housing is blocked Rotor is clogged</li> </ul>	<ul style="list-style-type: none"> <li>• Clean filter housing (Section 6) Clean Pump (Section 6)</li> </ul>
<ul style="list-style-type: none"> <li>• Insufficient water displaced</li> </ul>	<ul style="list-style-type: none"> <li>• Filter housing is clogged. Excessive loss in the supply line</li> </ul>	<ul style="list-style-type: none"> <li>• Clean filter housing (Section 6)</li> <li>• Reduce hose lengths to the minimum required, do not use unnecessary connecting parts</li> </ul>
<ul style="list-style-type: none"> <li>• Pump turns off after running a short while</li> </ul>	<ul style="list-style-type: none"> <li>• Water is very dirty Water Temperature is too high</li> </ul>	<ul style="list-style-type: none"> <li>• Clean pump (Section 6)</li> <li>• Ensure the water temperature does not exceed 35 ° C</li> </ul>

## 9. TECHNICAL PARAMETER

MODEL	PM2 13000W	PM2 15000W	PM2 18000W
Voltage (V)	AC 240 V 50 HZ	AC 240 V 50 HZ	AC 240 V 50 HZ
Power consumption (W)	180	215	315
Maximum flow (L/H)	13000	15000	18000
Maximum Head (M)	5.2	5.8	6.2
Outlet connection	1-2"	1-2"	1-2"
Weight (kg)	5.5	5.5	5.5

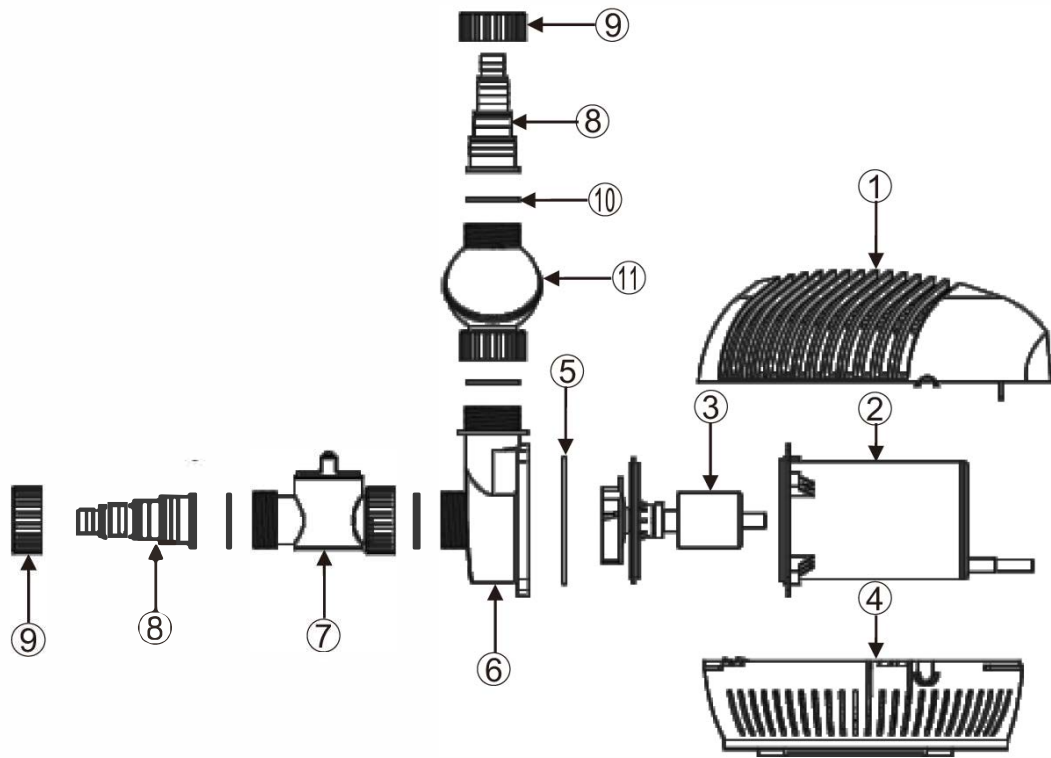

NO.	NAME
1	Filter cover - Upper
2	Motor
3	Impeller/rotor/shaft
4	Filter cover - Lower
5	O ring
6	Impeller cover
7	Flow adjuster
8	Outlet fitting / inlet fitting
9	Lock nut
10	Gasket
11	Outlet swivel









White International Pty Ltd
Limited Product Warranties
TERMS & CONDITIONS

This warranty is given in addition to the consumer guarantees found within the Australian Competition and Consumer Act 2010 (Cth) for goods purchased in Australia and the Consumer Guarantees Act 1993 NZ for goods purchased in New Zealand:

1) White International Pty Ltd / White International NZ Ltd (White International) warrant that all products distributed are free from defects in workmanship and materials, for their provided warranty period as indicated on the top or opposite side of this document. Subject to the conditions of the warranty, White International will repair any defective products free of charge at the premises of our authorised service agents throughout Australia and New Zealand if a defect in the product appears during the warranty period. If you believe that you have purchased a defective product and wish to make a claim under this warranty, contact us on our Sales Hotline on 1300 783 601, or send your claim to our postal address or fax line below and we will advise you as to how next to proceed. You will be required to supply a copy of your proof of purchase to make a claim under this warranty.

2) This warranty excludes transportation costs to and from White International or its appointed service agents and excludes defects due to non-compliance with installation instructions, neglect or misuse, inadequate protection against the elements, low voltage or use or operation for purposes other than those for which they were designed. For further information regarding the suitability of your intended application contact us on our Sales Hotline on 1300 783 601. If you make an invalid claim under this warranty, the original product will be sent back to you unrepaired.

3) This warranty refers only to products sold after the 1st January 2012, and is not transferable to another product type and only applies to the original owner, purchaser or end user, and is in addition to the consumer guarantees found within the Competition and Consumer Act 2010 (Cth) for goods purchased in Australia and the Consumer Guarantees Act 1993 (NZ) for goods purchased in New Zealand.

4) Our goods come with guarantees that cannot be excluded under the Australian Consumer Law. You are entitled to a replacement or refund for a major failure and for compensation for any other reasonably foreseeable loss or damage. You are also entitled to have the goods repaired or replaced if the goods fail to be of acceptable quality and the failure does not amount to a major failure.

5) To the fullest extent permitted by law, White International excludes its liability for all other conditions or warranties which would or might otherwise be implied at law. To the fullest extent permitted by law, White International's liability under this warranty and any other conditions, guarantees or warranties at law that cannot be excluded, including those in the Competition and Consumer Act 2010 (Cth), is expressly limited to:

(a) in the case of products, the replacement of the product or the supply of equivalent product, the payment of the cost of replacing the product or of acquiring an equivalent product or the repair of the product or payment of the cost of having the product repaired, is at the discretion of White

International or a 3rd party tribunal elected under the Competition and Consumer Act 2010 (Cth) for goods purchased in Australia and the Consumer Guarantees Act 1993 (NZ) for goods purchased in New Zealand; and

6) To the fullest extent permitted by law, this warranty supersedes all other warranties attached to the product or its packaging.

7) In the case of services, supplying the services again or the payment of the cost of having the services supplied again, is at the discretion of White International or a 3rd party tribunal elected under the Competition and Consumer At 2010 (Cth) for goods purchased in Australia and the Consumer Guarantees Act 1993 (NZ) for goods purchased in New Zealand.

8) Our warranty commences from the date of purchase of the above mentioned pumps. Proof of purchase is required before consideration under warranty is given. Record your date of purchase in the space below and retain this copy for your records.

Date of Purchase .....
Model Purchased .....

WHITE INTERNATIONAL PTY LTD
60 Ashford Ave Milperra NSW 2214
PO Box 304 Milperra LPO NSW 2214
Customer Service Hotline 1300 783 601
Fax 02 9783 6001
Email Sales: pumpsales@whiteint.com.au
www.whiteint.com.au

WHITE INTERNATIONAL NZ LTD
15G Kerwyn Avenue
East Tamaki, Auckland 2013, New Zealand
Customer Service Hotline 0800 509 506
Customer Service Faxline 0800 804 344
Email Sales: sales@whiteint.co.nz
www.whiteint.co.nz